

SWINGO L



DSCL12100610SK01-0110

H	L	A	B	C	D	E	F	G
1210	610	25	1115	90	25	95	60-70	77-87
I	J	K	M	N	O	P		
40-50	-	min.100	50	-	-	-		

26.3	kg
6.9	l
599	W

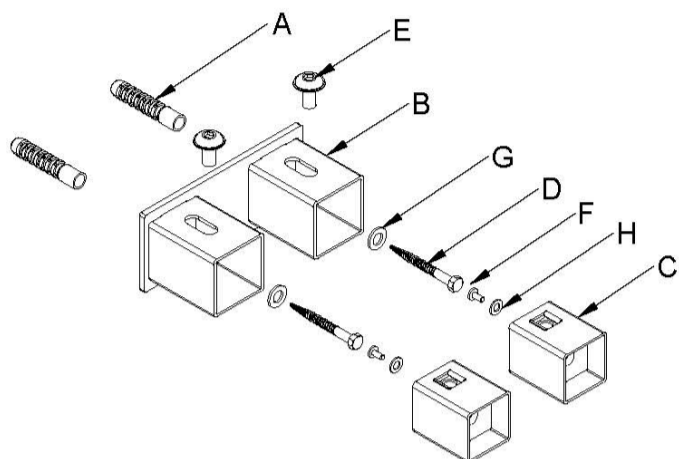

A 4x 10x50	B 2x	C 4x	D 4x M6x60
E 4x M6x10	F 4x M6x12	G 4x D18	H 4x D12

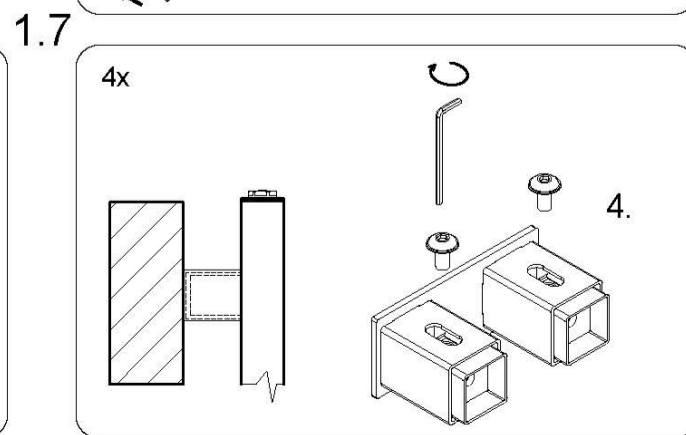
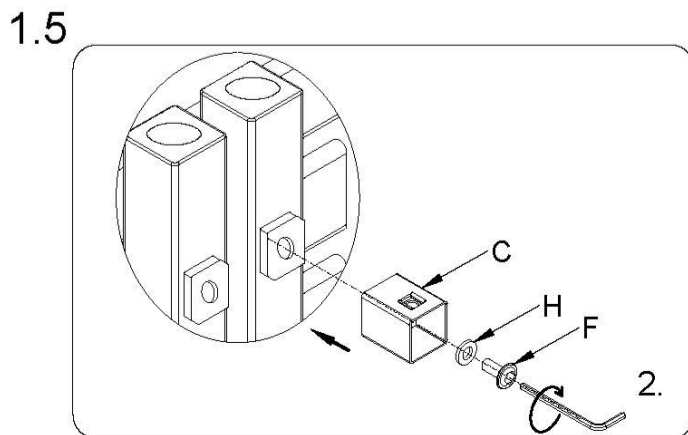
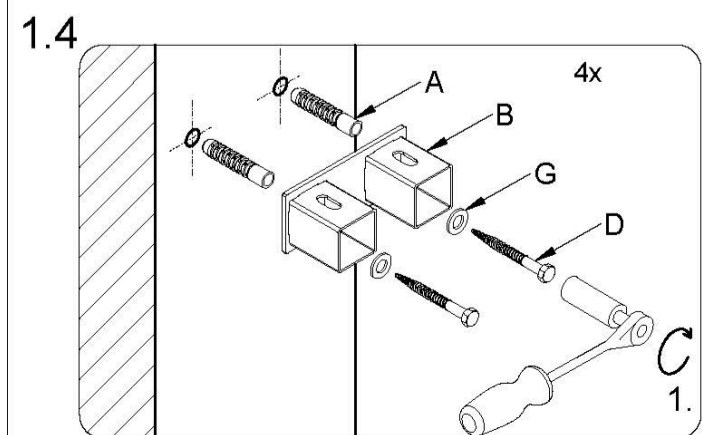
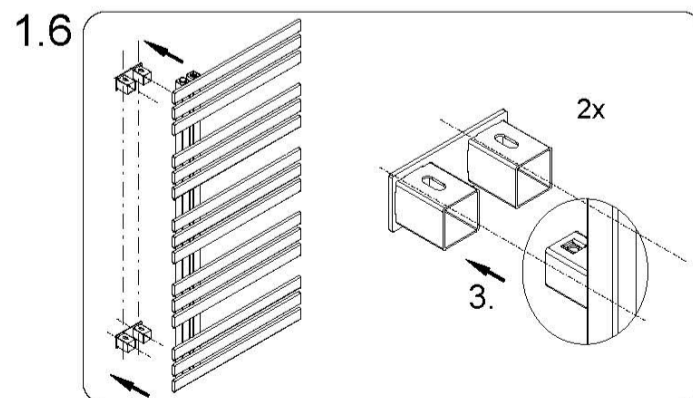
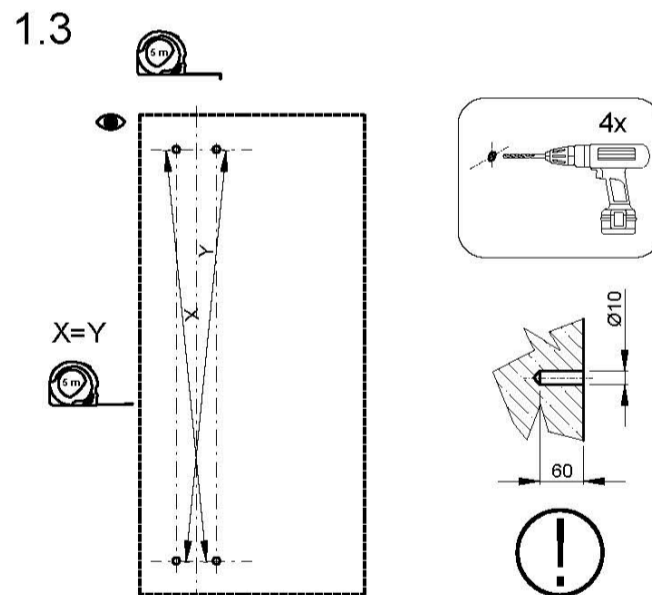
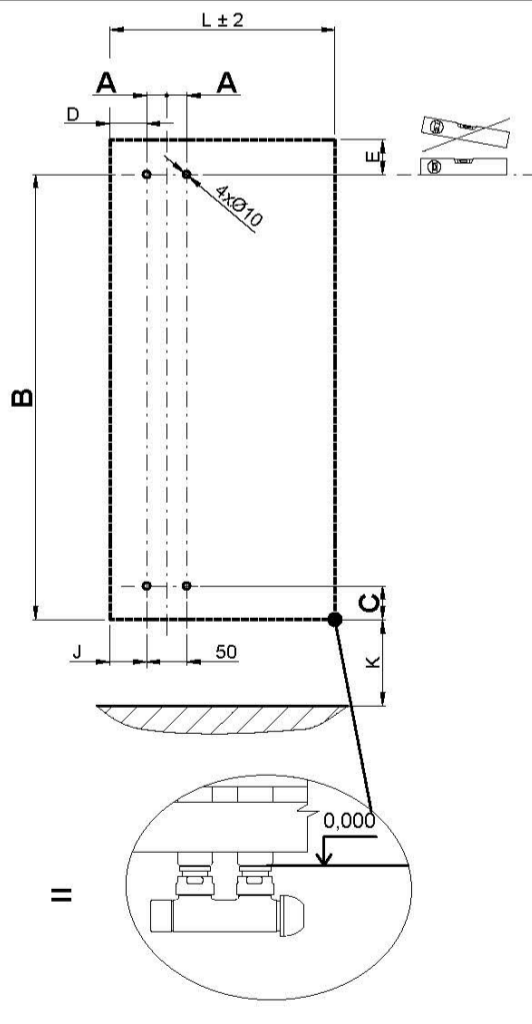
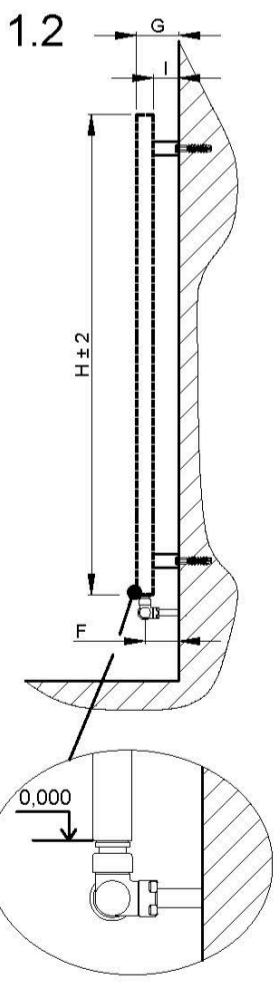
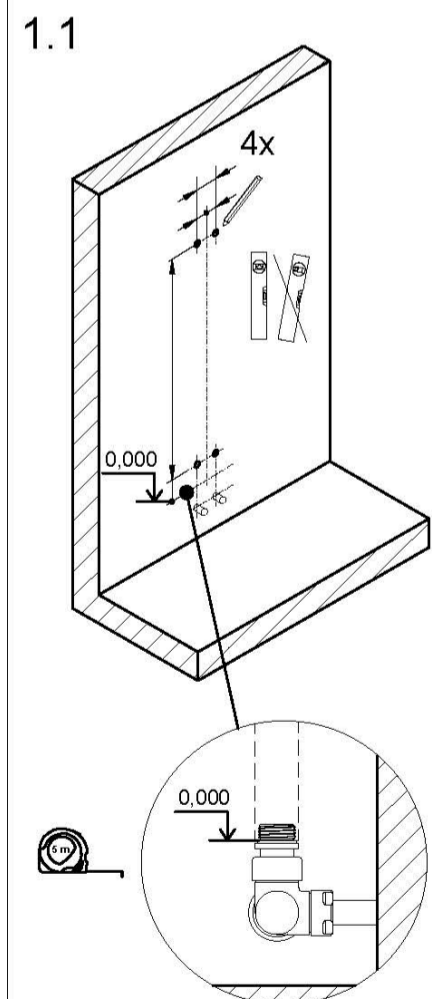
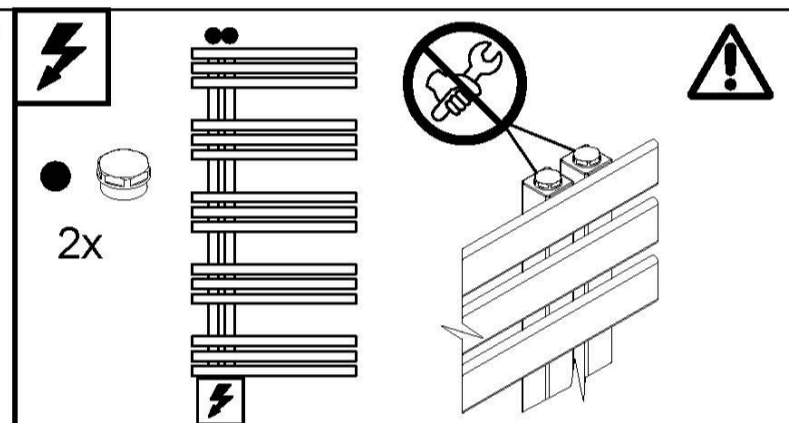
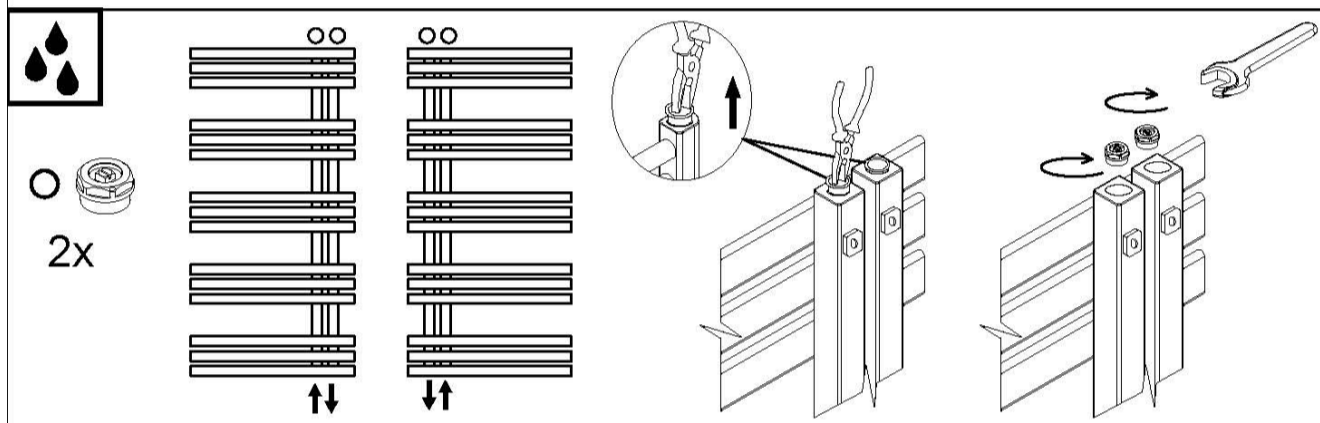
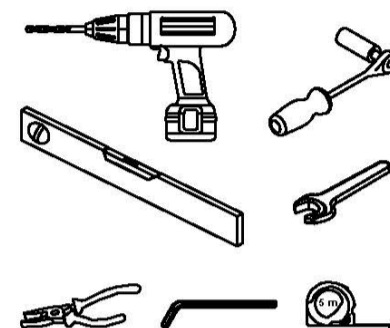

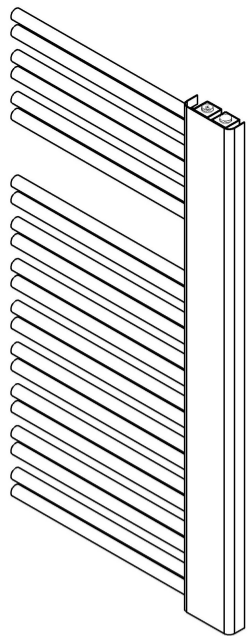

SWINGO L



DSCL16100610SK01-0110

H	L	A	B	C	D	E	F	G
1610	610	25	1515	90	25	95	60-70	77-87
I	J	K	M	N	O	P		
40-50	-	min.100	50	-	-	-		

35.7	kg
10.4	l
819	W

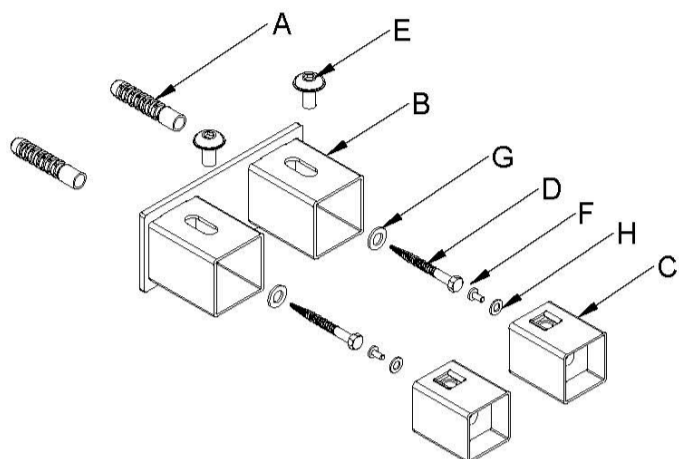

A 4x 10x50	B 2x	C 4x	D 4x M6x60
E 4x M6x10	F 4x M6x12	G 4x D18	H 4x D12

